



PUMA™ VTOL KIT

AeroVironment's Puma™ VTOL (vertical takeoff and landing) Kit is designed for plug-and-play integration into Puma AE small unmanned aircraft systems (SUAS). The VTOL Kit expands the operational capabilities of the combat-proven Puma systems in urban environments as no runway or large open space is required for launch and recovery, allowing operators to launch anywhere, anytime.

Available as an add-on option for new Puma 2 AE and Puma 3 AE system orders and as a retrofit kit, existing Puma AE customers can upgrade fielded systems with minimal modifications to the aircraft's airframe and with simple software upgrades. Removable, the kit will allow operators to transition between fixed-wing and VTOL to suit varying mission needs with a single aircraft.

Expanding Operational Capabilities

PUMA™ VTOL KIT

DISTINCTIONS



» LAUNCH AND RECOVERY
Vertical Takeoff and Landing (VTOL)



» COMPATIBILITY
Puma™ 2 AE & Puma™ 3 AE



» SETUP TIME
Under 5 min

SPECIFICATIONS

TOTAL PAYLOAD CAPACITY	Mantis™ i45/i45 N (2 lb) + Universal Transit Bay (2 lb)
ENDURANCE	1.5 hr with PS2500 battery 1.2 hr with Puma™ Smart Battery
OPERATING ALTITUDE	Launch & recovery 7K ft Density Altitude (DA) Max. flight altitude 10K ft DA
WEIGHT	7 lb (3.2 kg) VTOL Kit
MAX WIND RESISTANCE	15 kts
ASSEMBLY	Minimal, tool-free design*
ENVIRONMENTAL RATING	All-weather (excluding water landing)

*PATH TO UPGRADE

- Puma™ avionics software update required (fully backwards compatible)
- INS/GPS software update required (fully backwards compatible)
- Initial non-permanent install of VTOL avionics required (screw attachment)
- Upgraded Puma™ motor recommended
- Crysalis™ GCS required

KIT COMPONENTS

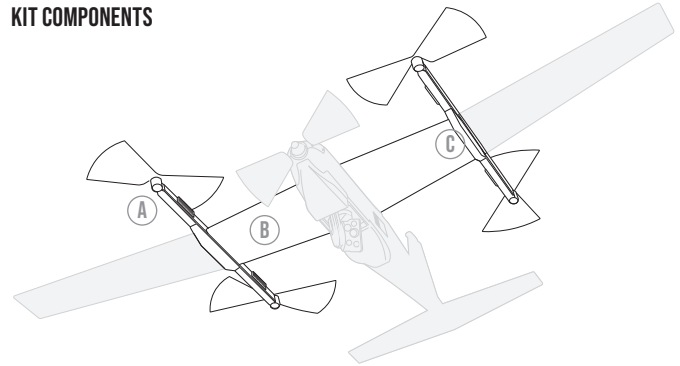

A VTOL boom assemblies (2)

B Pre-wired center wing (1)

C Batteries, removable & rechargeable (1 per boom)

Avionics module (1) - *Not shown*

Fastening hardware (1) - *Not shown*

KEY FEATURES

- » Automated one-button launch & recovery in confined environments
- » Highly reliable automated takeoff & landing with or without GPS
- » Single-case packout maintaining a minimal logistical footprint
- » Maintains Puma™ all-weather rating (excludes water landing)
- » Available as an add-on or retrofit kit

